



Current Transformer

Model 145MR

APPLICATION:

Relaying and metering

FREQUENCY:

50-400 Hz.

INSULATION LEVEL:

600 Volts. 10 kV BIL. full wave

WINDOW DIAMETER:

6.00"

APPROXIMATE WEIGHT:

83 lbs.

CONNECTIONS:

-Terminals are brass studs No. 10-32 UNF with one flat washer, lockwasher, and regular nut.



Model	141MR
Window Size	6.00
Width	11.10
Height	11.47
Depth	6.00

CERTIFICATIONS:



MODEL 145MR
Window Diameter 6.00"
Approximate weight: 83 lbs.

Catalog Number	Relay Class	Continuous Thermal	
		@ 30°C	@ 50°C
145-601MR	C200	2.0	1.5
145-122MR	C400	1.5	1.0
145-202MR	C800	1.33	1.0
145-302MR	C800	1.0	0.8
145-402MR	C800	1.0	0.6
145-502MR	C800	0.8	0.6

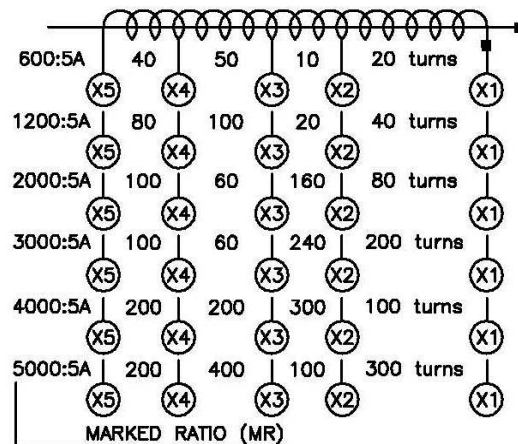
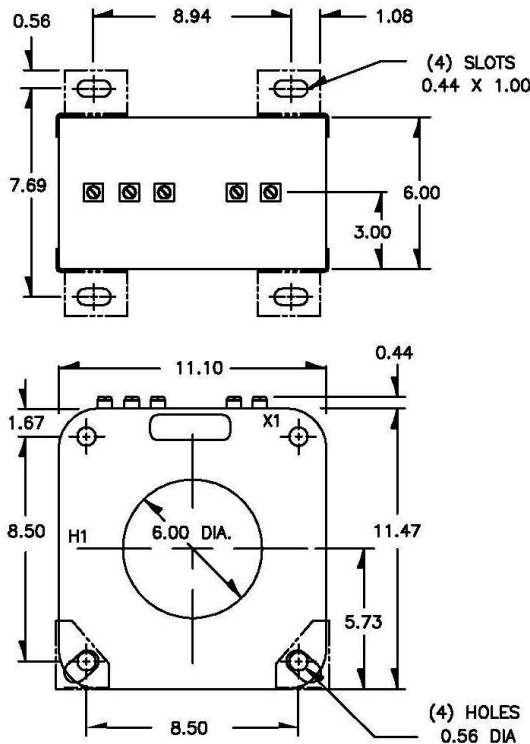

Products are manufactured in a plant whose quality management system is certified / registered as being in conformity with ISO 9001

EXCITATION CURVE

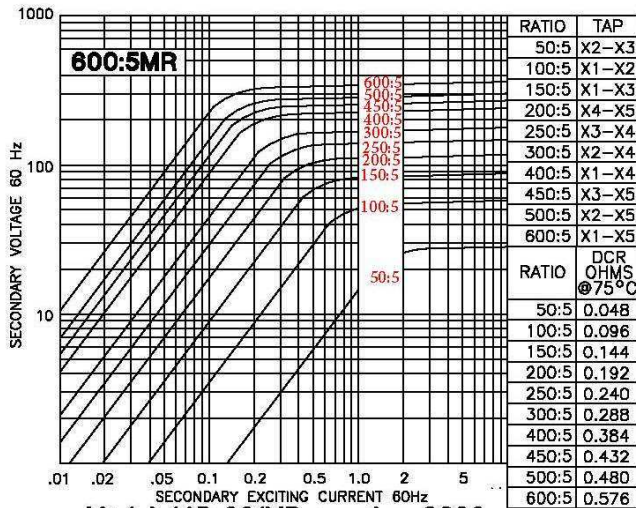

Model 145-601MR - rating C200
TRF= 2.0 @ 30°C, 1.5 @ 55°C amb.

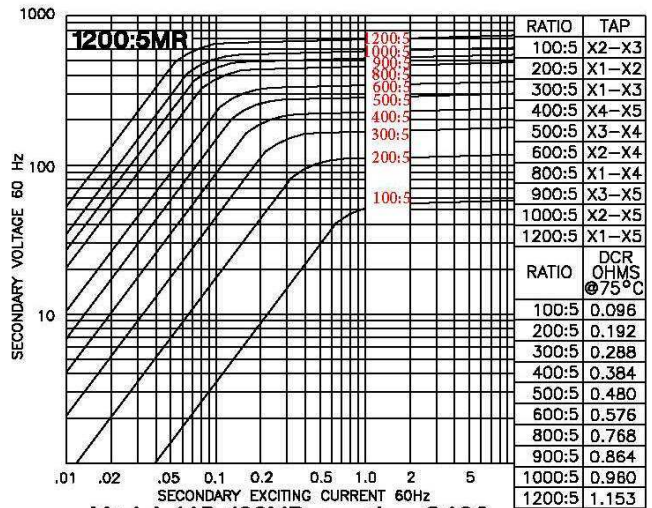

Model 145-122MR - rating C400
TRF= 1.5 @ 30°C, 1.0 @ 55°C amb.

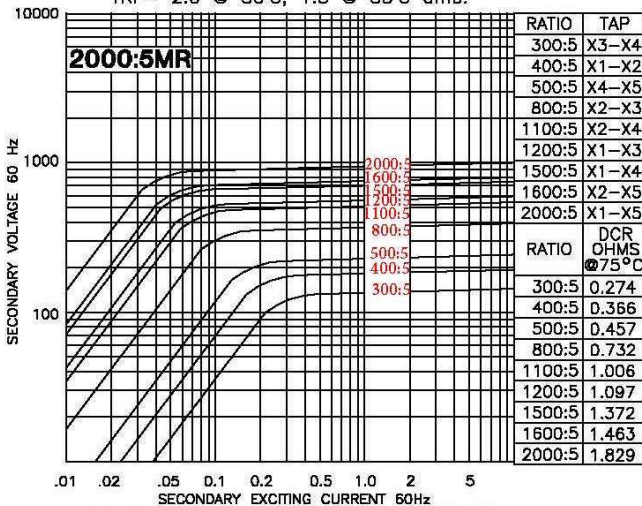

Model 145-202MR - rating C800
TRF= 1.33 @ 30°C, 1.0 @ 55°C amb.

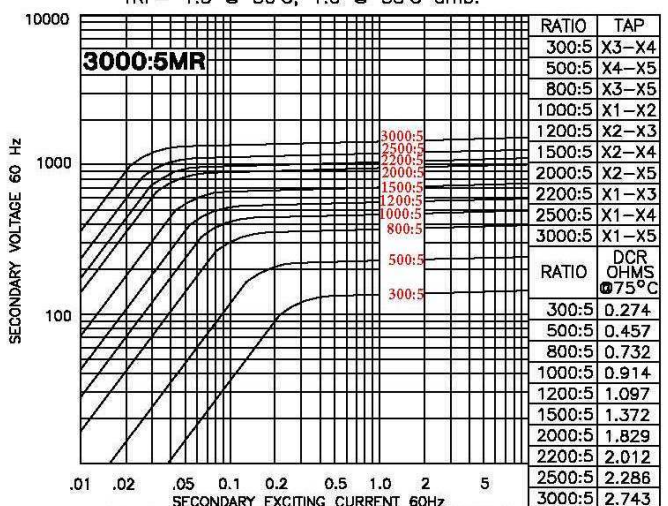

Model 145-302MR - rating C800
TRF= 1.0 @ 30°C, 0.8 @ 55°C amb.

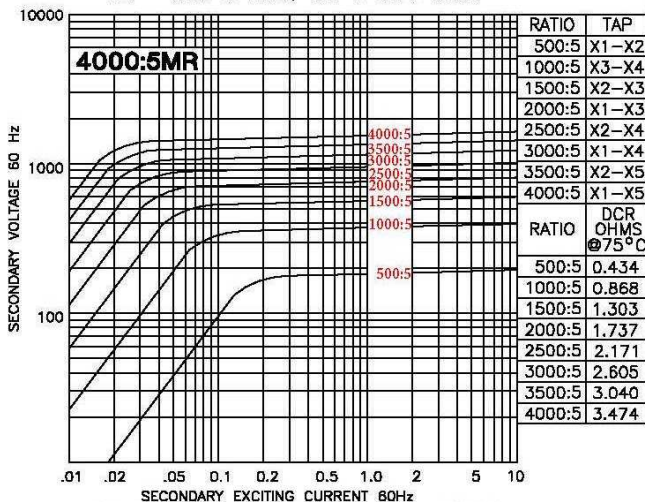

Model 145-402MR - rating C800
TRF= 1.0 @ 30°C, 0.6 @ 55°C amb.

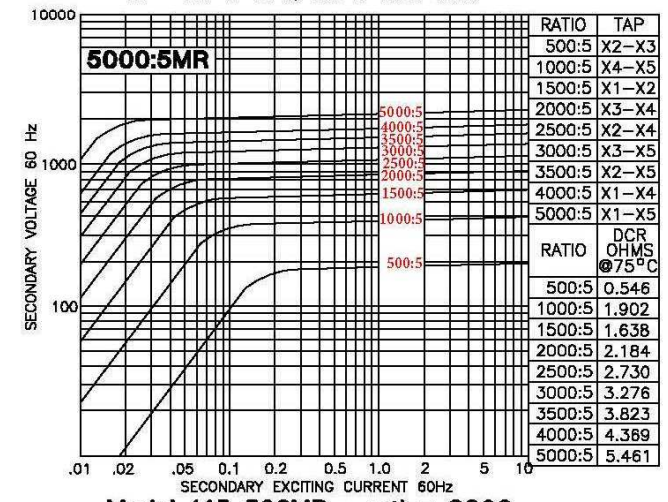

Model 145-502MR - rating C800
TRF= 0.8 @ 30°C, 0.6 @ 55°C amb.