



Current Transformer

Model 142MR

APPLICATION:

Relaying and metering

FREQUENCY:

50-400 Hz.

INSULATION LEVEL:

600 Volts. 10 kV BIL. full wave

WINDOW DIAMETER:

7.25"

APPROXIMATE WEIGHT:

31 lbs.

CONNECTIONS:

-Terminals are brass studs No. 10-32 UNF with

one flat washer, lockwasher, and regular nut

-Mounting kit – 59-0215 (CR) and 59-0216 (CL)



CERTIFICATIONS:



Model	142MR
Window Size	7.25
Width	11.10
Height	11.47
Depth	3.00

MODEL 142MR
 Window Diameter 7.25"
 Approximate weight: 31 lbs.

Catalog Number	Relay Class	Continuous Thermal	
		@ 30°C	@ 50°C
142-601MR	C50	2.0	2.0
142-122MR	C200	1.5	1.0
142-202MR	C200	2.0	1.5
142-302MR	C200	1.0	0.8
142-402MR	C200	1.0 </td <td>0.8</td>	0.8
142-502MR	C200	1.0	0.8

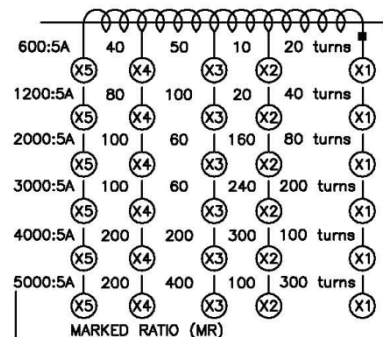
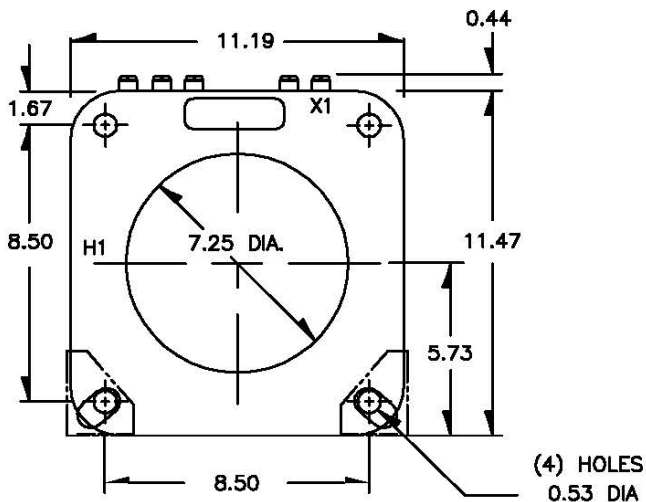
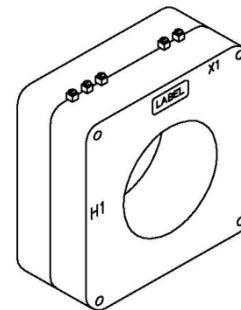
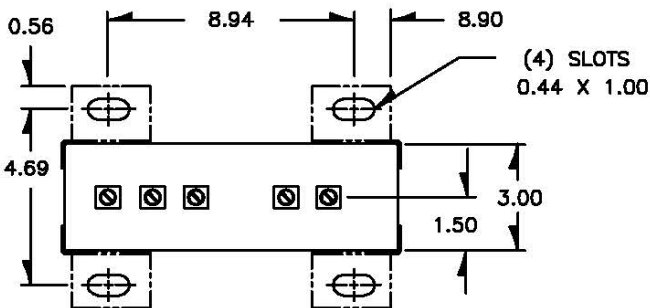

EXCITATION CURVE

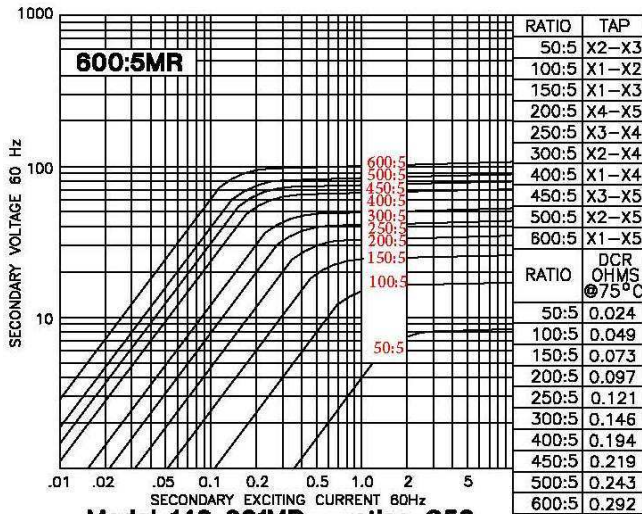

Model 142-601MR - rating C50
TRF= 2.0 @ 30°C, 2.0 @ 55°C amb.

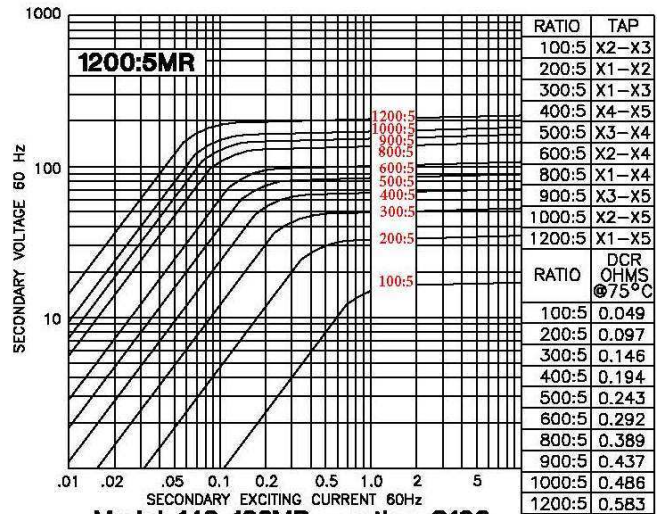

Model 142-122MR - rating C100
TRF= 1.5 @ 30°C, 1.0 @ 55°C amb.

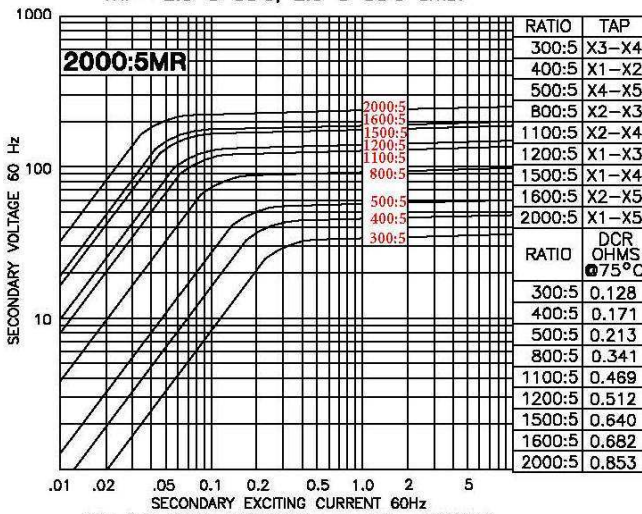

Model 142-202MR - rating C200
TRF= 2.0 @ 30°C, 1.5 @ 55°C amb.

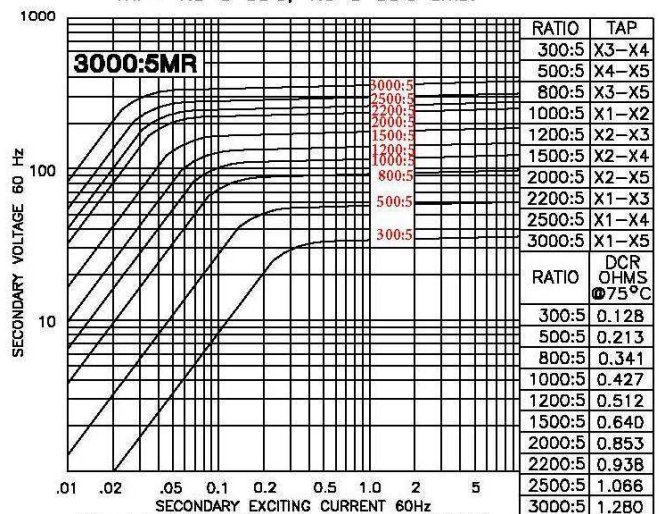

Model 142-302MR - rating C200
TRF= 1.0 @ 30°C, 0.8 @ 55°C amb.

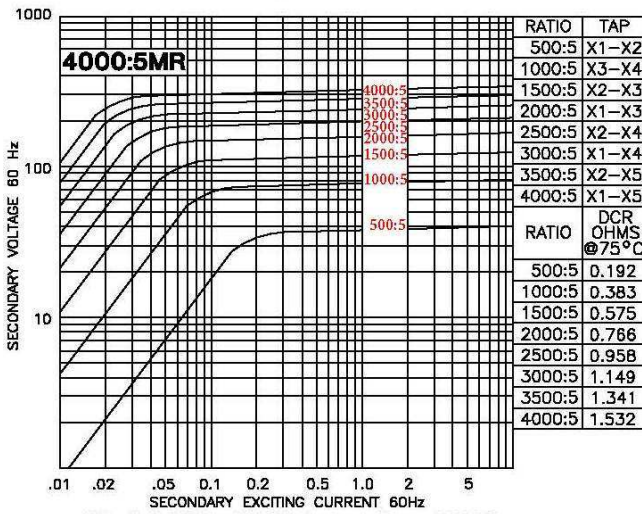

Model 142-402MR - rating C200
TRF= 1.0 @ 30°C, 0.8 @ 55°C amb.

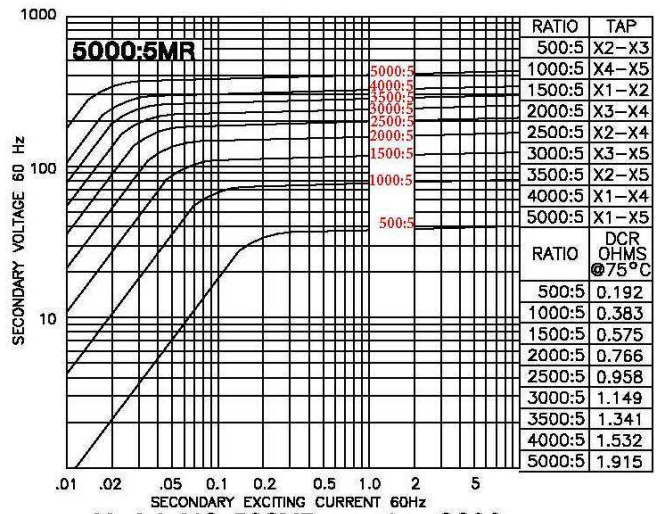

Model 142-502MR - rating C200
TRF= 1.0 @ 30°C, 0.8 @ 55°C amb.