

Installation and Operating Manual 262-300 Process Control Digital Meter Relay



**Crompton
262-300 Process Control
Digital Meter Relay**

Installation & Operating Manual

Crompton Instruments
Freebournes Road
Witham
Essex
CM8 3AH
England

Tel: +44 (0) 1376 509 509

Fax: +44 (0) 1376 509 511

E-Mail: crompton.info@tycoelectronics.com

Contents	Page
1.0 General	1 - 2
2.0 Unpacking	2
3.0 Installation	3 - 6
3.1 Safety Information	3
3.2 Installing Into a Panel	4
3.3 Wiring	4
3.4 Power Supply	4 - 5
3.5 Sensor Connections	5
3.5.1 Current Measurement of an Internally Powered Loop	5
3.5.2 Current Measurement of an Externally Powered Loop	6
3.5.3 Voltage Connection	6
4.0 Programming the Instrument	7 - 10
4.1 Programming Guide	7
4.2 Key Definitions	7
4.3 Entering Menu Mode	8
4.3.1 Moving Around The Menu	8
4.3.2 Entering A Submenu	8
4.3.3 Editing A Parameter	9
4.3.4 Returning From Submenus	9
4.4 The Menus	
4.4.1 The INPt (INPUT) Submenu	10
4.4.2 The SyS (System) Submenu	10
5.0 Operation	11
5.1 Run Mode Operation	11
5.2 Failure Modes	11
6.0 Specification	11
6.1 Process Specification	11
6.2 General Specification	11 - 12
7.0 Option Modules	12 - 16
7.0.1 Installing Modules	12
7.1 262-RLY Dual Relay Module	13
7.1.1 SLT1, SLT2 (Relay Module) Submenu	13
7.1.2 Relay Specification	13
7.2 62-ALG, Isolated Analogue Output Module	14
7.2.1 SLT1, SLT2 (Analogue output module) Submenu	14
7.2.2 Analogue output module Specification	14
7.3 Modbus Serial Communications Module, 262-MOD	15
7.3.1 SLT1, SLT2 (Communications) Submenu	15
7.3.2 Comms Module Specification	15 - 16
8.0 Mechanical Detail	17

1.0 General

The unit is a highly accurate and stable digital temperature indicator that accepts all commonly used temperature sensors. The unit can be used "stand alone" or, with the Modbus serial communications module option, as part of a larger system.

The case design enables option Modules to be easily installed without the need for dismantling or re-calibration. A range of Modules are available for:

- Relay outputs 262-RLY
- Isolated Analogue Output 262-ALG
- Modbus serial communication 262-MOD

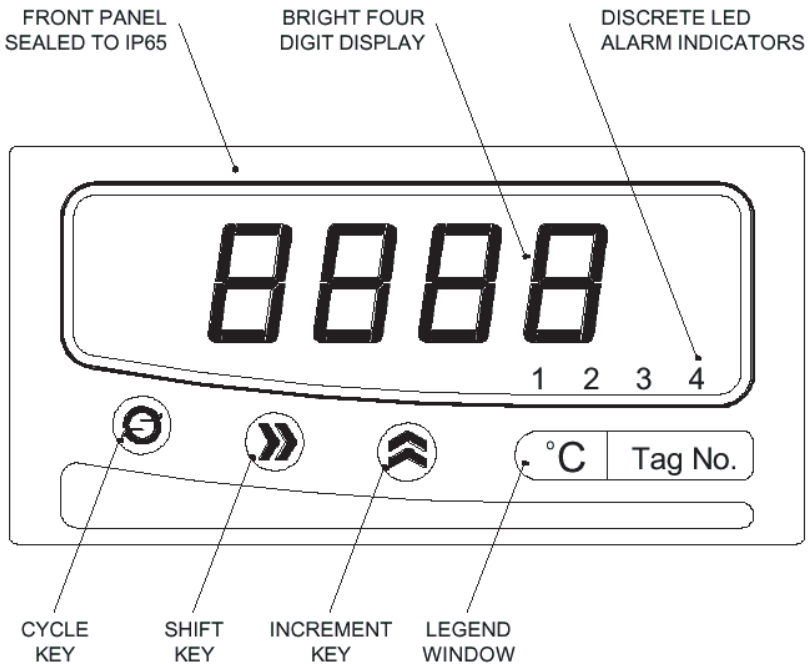

1.0 General continued

The diagram shows the rear panel positions for all electrical connections.

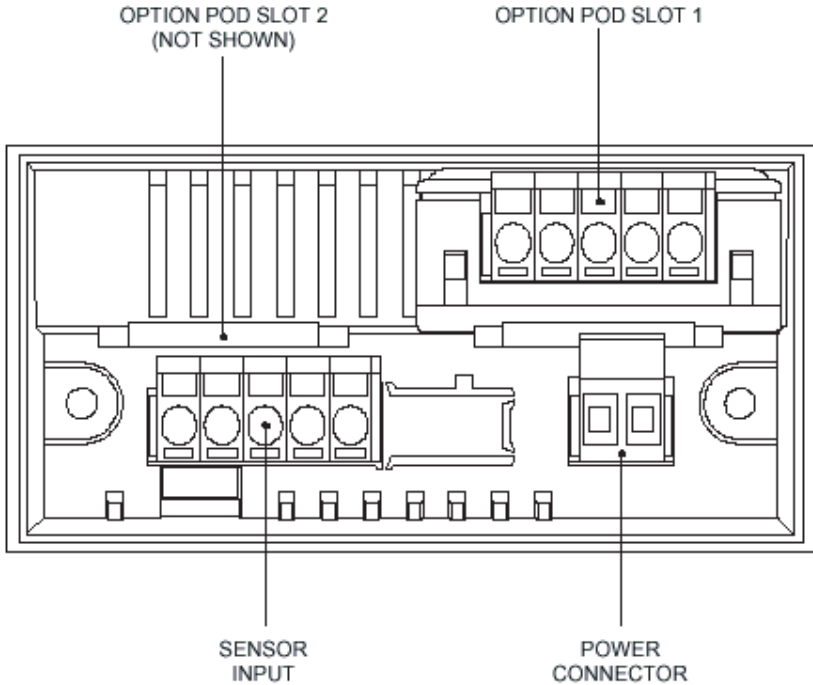

2.0 Unpacking

Please inspect the instrument carefully for any signs of shipping damage. The packaging has been designed to afford maximum protection, however, we cannot guarantee that mishandling will not have damaged the instrument. In the case of this unlikely event, please contact your supplier immediately and retain the packaging for subsequent inspection.

3.0 Installation

THIS SECTION FOR USE BY COMPETENT PERSONNEL ONLY

3.1 Safety Information

WARNING	READ SAFETY INFORMATION BELOW BEFORE INSTALLATION
WARNING	Hazardous voltages may be present on the terminals the equipment must be installed by suitably qualified personnel and mounted in an enclosure providing protection to at least IP20.
ISOLATION	<p>The power supply terminals and associated internal circuitry are isolated from all other parts of the equipment in accordance with BS EN61010-1 for connection to a Category II supply (pollution degree 2).</p> <p>Functional isolation (500v max) is provided between input and output circuits, and between inputs and communications (where fitted).</p> <p>Any terminals or wiring connected to the input, output or communications terminals which are accessible in normal operation must ONLY be connected to signals complying with the requirements for Safety extra low voltage (SELV) circuits.</p>
WARNING	If not installed in accordance with these instructions, protection against electrical hazards may be impaired.

- Installation overvoltage category - 2 (as per BS EN61010-1)
- The Mains supply to the equipment must be protected by an external 1 Amp fuse and a suitable switch or circuit breaker which should be near the equipment.
- The equipment contains no user serviceable parts.

3.2 Installing into a Panel

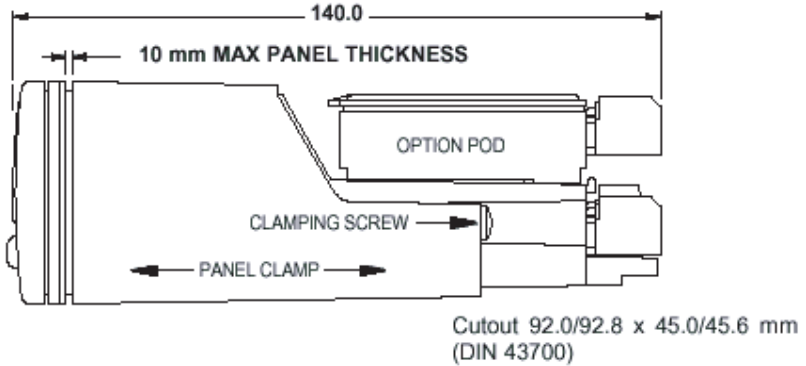

Refer to section 8.0 for Mechanical Detail.

The maximum panel thickness is 10mm. The instrument case has an integral gasket which forms a seal when the instrument is tightened against the panel.

The panel should be clean, smooth and at least 1.6mm thick for the seal to be effective.

- **WARNING** Use only the retaining screws provided to clamp the instrument to the panel (screws must be tightened sufficiently to effect a seal but must never be overtightened).

3.3 Wiring

All connections are made to sockets which are removable for ease of maintenance. Installation should be undertaken in accordance with relevant sections of BS6739 - British Standards code of practice for "Instrumentation in Process Control Systems: Installation design and practice".

3.4 Power Supply

The Power supply rating will be indicated on the top of the instrument, ensure it is correct for the application. The Mains supply to the equipment must be protected by an external 1 Amp fuse and a suitable switch or circuit breaker which should be near the equipment.

3.4 Power Supply Continued

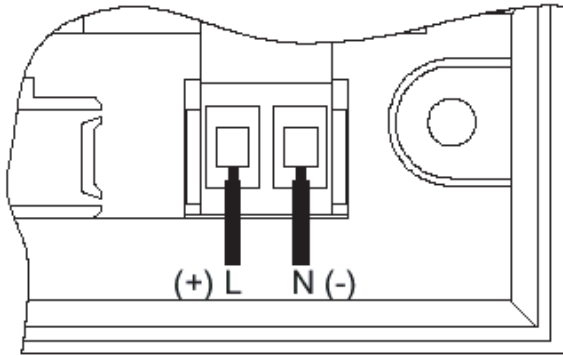

Wires are retained by screws. Ensure that the exposed section of the wire is fully inserted and that no loose strands are exposed.

3.5 Sensor Connections

All sensor connections are made via a five way "fast wiring" socket at the rear of the unit (wire size 0.5 to 1.5mm²).

3.5.1 Current Measurement of an Internally Powered Loop

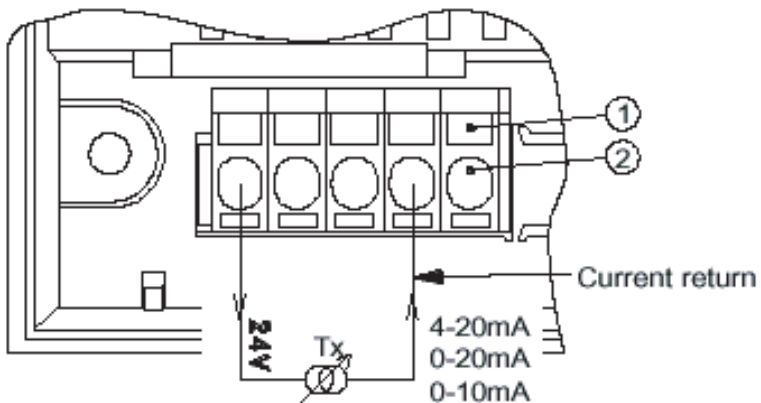

A 24V internal power supply is available to power external field transmitters.

3.5.2 Current Measurement of an Externally Powered Loop

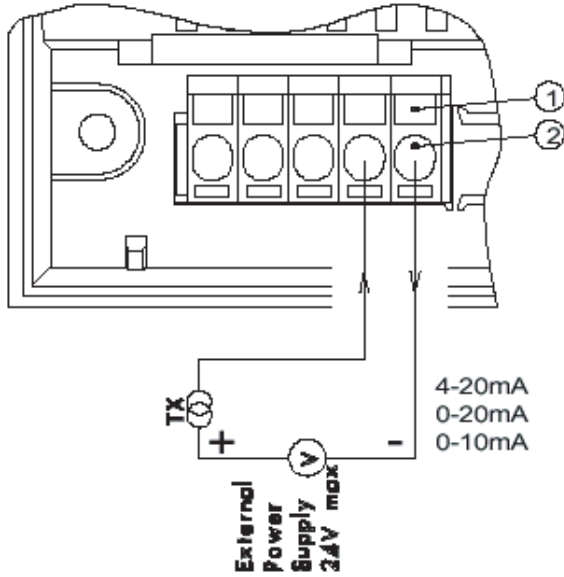

3.5.3 Voltage Connection

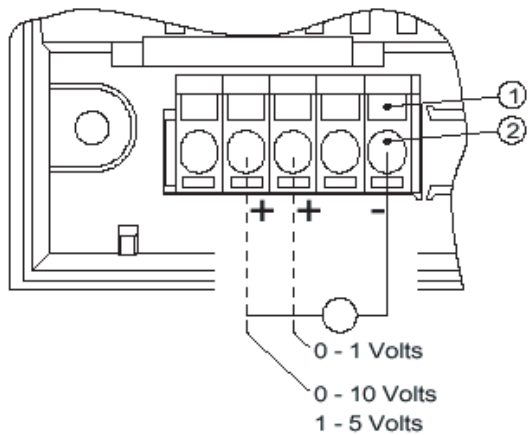

To make a connection: Insert small screwdriver blade into tension clamp orifice, (1) push and twist to deflect clamp into open position. Do not lever screwdriver thus forcing connector body sideways. Insert conductor tail sufficiently into (2) then release screwdriver. Ensure no loose wire strands protrude.

4.0 Programming the Instrument

The unit is a microprocessor based instrument enabling it to satisfy a variety of applications. All programming is available from the front panel or via a PC using the RS485 Modbus communications module.

4.1 Programming Guide

The unit has three operating modes. These are :

- RUN (DISPLAYS PROCESS VARIABLE)
- MENU
- EDIT

RUN is the principal mode of operation, which displays the Process Variable from which all other modes are accessed. The unit will always time-out back to this mode after one minute.

MENU mode provides access to the programmable parameters.

EDIT mode is entered from Menu Mode and allows the user to inspect and modify a parameter.

4.2 Key Definitions

The indicator is programmed using the three front panel keys, A,B and C are shown to assist the tutorial.

CYCLE (A), SHIFT (B) and INC (C) keys are pressed singularly.

ESCAPE (A&B), ENTER (B&C) and CLEAR (A&C) are obtained by simultaneously pressing the two keys.

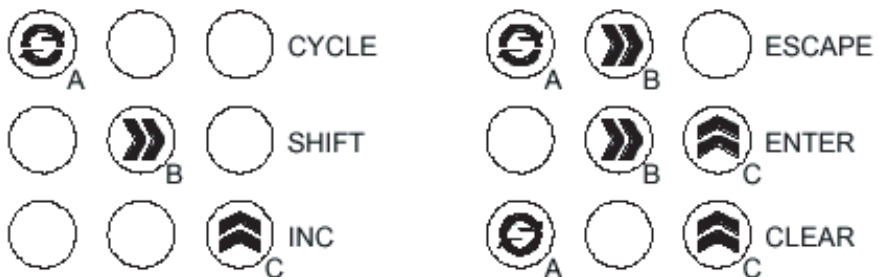

4.3 Entering Menu Mode

The Root Menu mode is accessed from "Run" by pressing ENTER (B&C) followed by CYCLE (A). The display will now show "inPt". In order to understand what this means, the following diagram shows where we are within the basic Root menu.

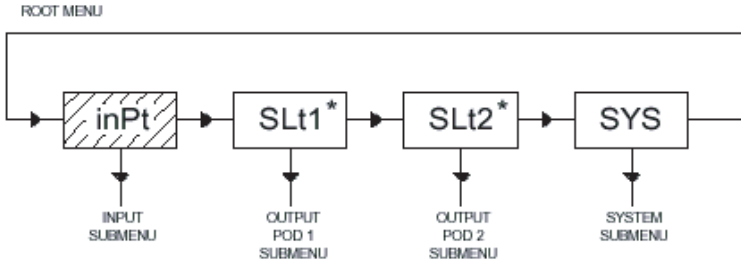

* Slot menus only appear when respective option modules are fitted.

4.3.1 Moving Around The Menu

One can browse through the Root menu by pressing CYCLE (A) which moves the menu position from left to right (after reaching SYS, the menu position wraps around to the start).

4.3.2 Entering A Submenu

To enter a submenu, first cycle around the Root menu until the required submenu is displayed. For the purposes of this tutorial press the CYCLE (A) key until InPt is displayed. Pressing SHIFT (B) enters the Input Submenu.

tYPE will now be displayed. The diagram shows our position in relation to other items in the menu.

Pressing CYCLE (A) moves left to right, wrapping around at the end. The unit alters items in the menu list depending upon settings made.

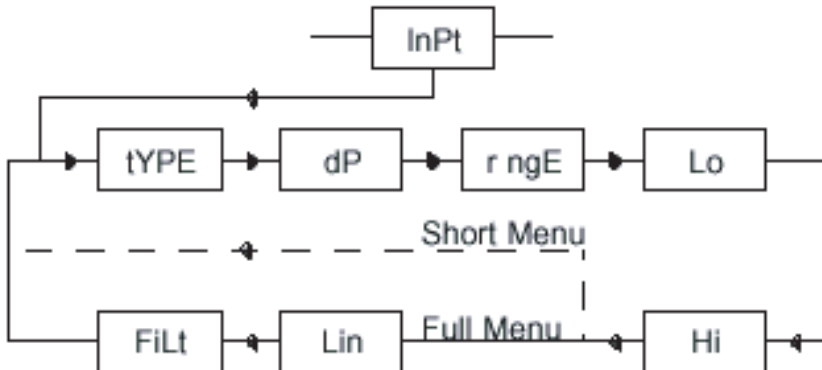

4.3.3 Editing A Parameter

The items displayed in the menu can either be submenus, parameters or numbers, most of the items in the Inputs menu are parameters which can be edited.

Press the CYCLE (A) key until tYPE is displayed, then press SHIFT (B).

The current setting will now be shown flashing. This item is changed by pressing the INC (C) key.

The choice of options available is as follows:

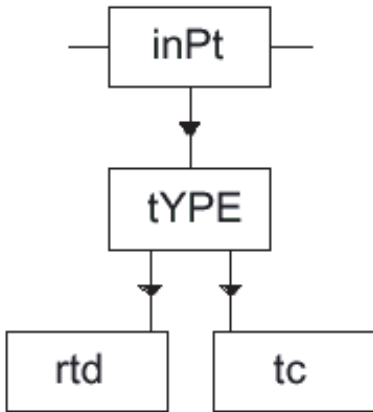

Press the INC (C) key until "crnt" is displayed.

Note that whilst the display is flashing, the option on the display has not been saved to memory. To select an option, the ENTER key sequence is used. Press ENTER (B&C). The display will stop flashing momentarily before returning to Menu mode. The system automatically steps on to the next entry to speed the process of programming. This method of editing parameters is repeated throughout the menu structure.

4.3.4 Returning From Submenus

To return up from the inPt menu to the root menu wait for 1 minute or press the ESCAPE (A&B) key.

Pressing the ESCAPE key from our current position in the Inputs submenu takes us back to the Root menu. The menu position will automatically step to the next menu item, if no modules are fitted the unit will show SYS, if modules are fitted SLt1 or SLt2 will be shown.

The Root menu, as its name suggests is not a submenu. Pressing the ESCAPE (A&B) key sequence whilst in the Root menu will take the user out of Menu mode and into Run mode. Thus the process variable will be shown on the display. Refer to section 5.2 if an error code is shown after programming in menu mode.

4.4 The Menus

4.4.1 The INPt (INPUT) Submenu

The INPt submenu is used to program all the characteristics of the input sensor and any signal conditioning that may be required. The selection of an option in the list may affect items further down. Therefore, during programming, the user should start at the top of the menu and work down, to avoid setting an option which may later become obsolete. Short menu items shown in bold.

<u>TITLE</u>	<u>OPTIONS</u>	<u>DETAIL</u>
tYPE	crnt, VoLt	Set Current or Voltage
dP	888.8, 88.88, 8.888, 8888	Defines decimal point location
rngE	4-20, 0-20, 0-10 mA	range setting, only for Current input
rngE	1-5, 0-1, 0-10	Voltage setting, only for Voltage input
Lo	000.0	Low engineering range, -999 to 9999
Hi	100.0	High engineering range, -999 to 9999
Lin	nonE, Sqrt, cust	Linearity: none, square root or custom *
FiLt	nonE, 2.5s, 10s, Adaptive	Input filtering or smoothing

* It is only possible to define custom characteristics via comms.

4.4.2 The SyS (System) Submenu

<u>TITLE</u>	<u>OPTIONS</u>	<u>DETAIL</u>
LiSt	FuLL, SHrt	Selects full or short menu
cLEn	oFF, on	Clear enable (option modules)
SPEn	oFF, on	Setpoint enable (option modules)
PASS	4 digit passcode	Modify any password code
oFFS	User defined offset	Take care when replacing sensor

Refer to section 7.0 for SLt menu structures.

5.0 Operation

5.1 Run Mode Operation

The normal display shown in this mode is the process variable.

<u>KEYPRESS</u>	<u>ACTION</u>
CYCLE (A)	View setpoints (Adjust value if SPEn enabled)
CLEAR (A&C)	Clear latched alarms (cLEn enabled)

5.2 Failure Modes

If the input is outside the measuring range of the instrument, the following error messages will be shown.

Input	Display
Over range	-----
Under range	-----

6.0 Specification @20 °C

6.1 Process Specification

Voltage Range	0-1 volts / 1-5 volts / 0-10 volts
Accuracy	0.05% FS
Thermal Drift	Zero 0.1µV / °C Span 100 ppm / °C
Current Range	0-20mA / 4-20mA / 0-10mA
Input Impedance	47 ohm (current) 1 Mohm (voltage)
Accuracy	0.05% FS
Thermal Drift	100 ppm / °C
Excitation	24V ±5% @ 50 mA

6.2 General Specification @ 20 °C

Input/Output Isolation	500VAC rms (galvanically isolated)
Update time	250 mS maximum
Time Constant (Filter off)	<1 second (to 63% of final value)
Filter Factor	Off, 2 Seconds, 10 Seconds or Adaptive
Warm-up time	2 minutes to full accuracy
Display Range	-999 to 9999
Power Supply	90-253 VAC 50/60 Hz, or optionally 20-35 VDC
Power Consumption	6VA Maximum (options fitted)

Environmental

Sealing to PANEL	IP65
Ambient Operating Range	-30 to +60 °C
Ambient Storage Temperature	-50 to +85 °C
Ambient Humidity Range	10 to 90% RH non condensing

APPROVALS

EMC	Emissions BS EN50081-1 Susceptibility BS EN50082-2
ELECTRICAL SAFETY	BS EN61010-1

Environmental Approvals for Tension Clamp Terminals

Low Temperature	IEC 68-2-1
Dry Heat	IEC 512-6-9
Damp Heat	IEC 512 -6-3
Damp Heat cyclical	IEC 68-2-30
Salt Spray	IEC 512-6-6
Sulphur Dioxide	IEC 68-2-46
Hydrogen Sulphide	IEC 68-2-16
Gas Tightness	IEC 512-Pr.11n

7.0 Option Modules

7.0.1 Installing Modules

Power must be removed from unit before adding/removing a module.

Slot 1 (alarm 1 and 2) should be positioned on the left side of the unit looking from the front to correspond to front panel alarm indicator, slot 2 (alarm 3 and 4) is positioned on the right.

To install an option module, slide back the cover to its next engaging position and push the module connection within the mating connector.

To remove an option module, disengage the supporting latch situated beneath the module by pushing the back cover forward, the module can then be lifted away from the instrument connector.

7.1 262-RLY Dual Relay Module

The relay module has two "change over" relays with a common wiper.

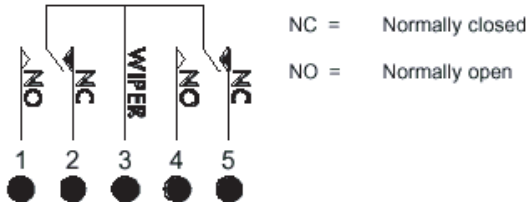

7.1.1 SLT1, SLT2 (Relay Module) Submenu

Each relay can be set as high or low alarm independently.

<u>TITLE</u>	<u>OPTIONS</u>	<u>DETAIL</u>
AL1	Hi, Lo	Alarm action
SEt1	User defined	PV at which the alarm triggers
HYS1	User defined	Hysterisis band (see below)
LAt1	oFF, on	Sets latching to on or off
inUI	oFF, on	Invert relay operation

Continues through for Relays 2 - 4 (when fitted).

Short menu items shown in bold.

Hysteresis Operation

7.1.2 Relay Specification

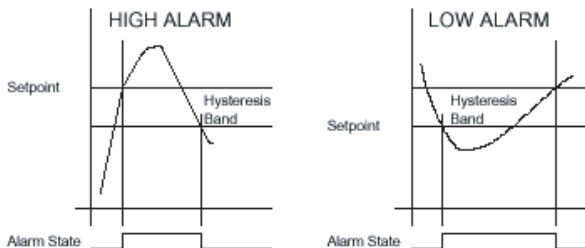

	<u>AC</u>	<u>DC</u>
Maximum Load	7A @ 250V	7A @ 30V
Maximum Power	1750VA	210W
Maximum Switching	250V	125V

Electrical Life 10⁵ operations at rated load

Mechanical Life 50 Million operations

7.2 262-ALG, Isolated Analogue Output Module

The re-transmission module (when fitted) is designed to provide 0-10mA, 0-20mA or 4-20mA output in active or passive modes. The output can be any portion of the display. The module can be used in two modes:

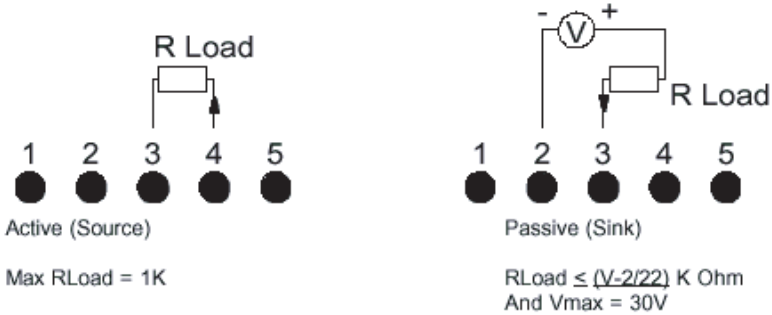

Note: Only one analogue output module can be fitted.

7.2.1 SLT1, SLT2 (Analogue output module) Submenu

TITLE	OPTIONS	DETAIL
SPan	4-20mA, 0-20mA, 0-10mA	User defined output current
rt lo	User defined	Low span range, to match display
rt HI	User defined	High span range, to match display

7.2.2 Analogue output module Specification

Minimum Current Output	> 0mA
Maximum Current Output	< 23mA
Accuracy	0.07% or 5µA, which ever is greater
Maximum External Power Supply	30V (passive mode)
Voltage Effect	0.2µA / V
Ripple Current	<3µA
Isolation	500V AC
Temperature Stability	1µA / °C

7.3 Modbus Serial Communications Module, 262-MOD

The diagram below shows a PC connected to Modbus modules.

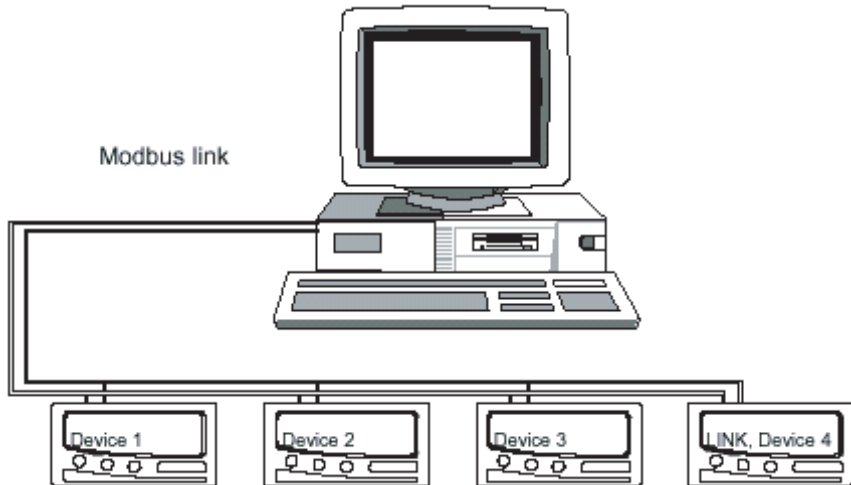

7.3.1 SLT1, SLT2 (Communications) Submenu

TITLE	OPTIONS	DETAIL
Addr	User defined	Instrument device number
baud	9.6, 19.2	User selected baud rate
Line	2, 4	4 Wire or 2 wire half duplex RS 485

7.3.2 Comms Module Specification

Configuration, system I/O and display unit PC communication.

Physical Layer	4 wire or 2 wire half duplex RS485
Isolation	500V AC
Maximum Fan out	32 units
Software Baud Rate	19,200 or 9,600
Protocol	Modbus RTU format

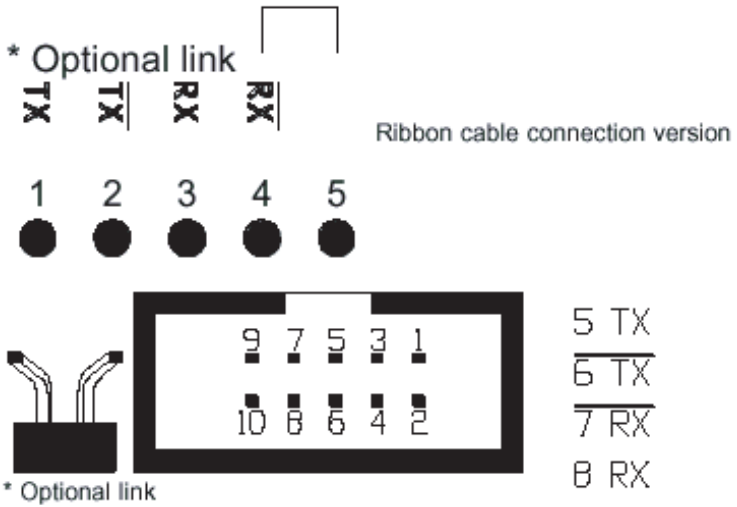

* Connection of the link connects a 100 ohm termination resistor across pins 7 and 8. This resistor should only be selected for the instrument furthest away from the host.

Full details of the modbus protocol are supplied separately with the module.

8.0 Mechanical Detail

Material	ABS/PC
Weight	200g
Flammability	IEC707 FV0
Module weight	40g typical
Panel cutout	92mm x 45mm

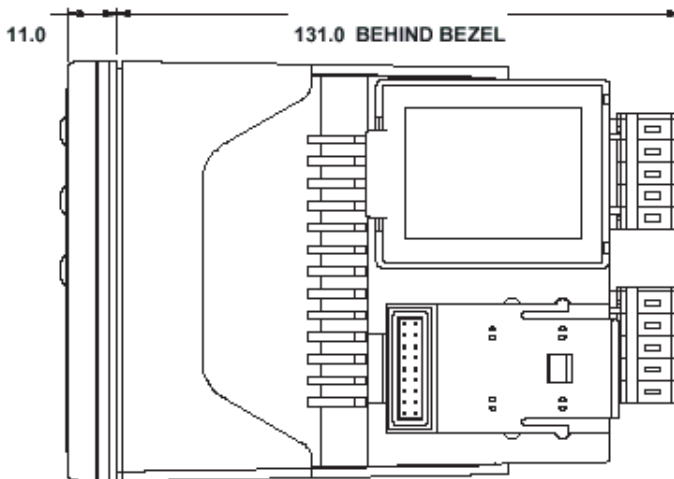
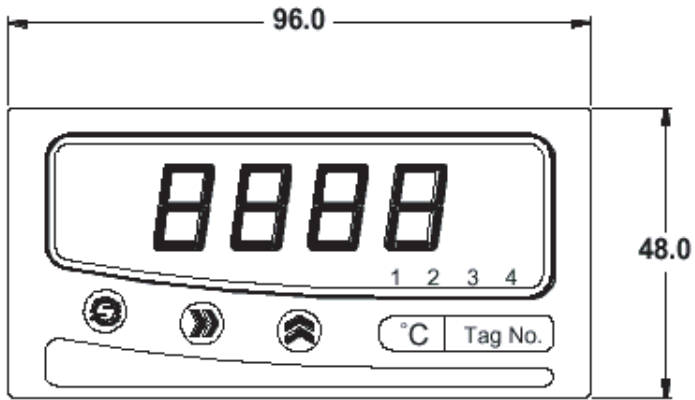

The Information contained in these installation instructions is for use only by installers trained to make electrical power installations and is intended to describe the correct method of installation for this product. However, Tyco Electronics has no control over the field conditions which influence product installation.

It is the user's responsibility to determine the suitability of the installation method in the user's field conditions. Tyco Electronics' only obligations are those in Tyco Electronics' standard Conditions of Sale for this product and in no case will Tyco Electronics be liable for any other incidental, indirect or consequential damages arising from the use or misuse of the products. Crompton is a trade mark.



Tyco Electronics UK Limited
Crompton Instruments

Freebournes Road, Witham, Essex, CM8 3AH, UK
Tel: +44 1376 509 509 Fax: +44 1376 509 511

<http://energy.tycoelectronics.com>