

Compact ANSI Switchboard Analogue Meters

Products Covered

007-05A	007-05C	007-05F	007-05G	007-05R
007-05V	007-052	007-053	007-054	007-055
007-056	007-057			



Caution: Risk of Danger

These instructions contain important safety information: Read before starting installation or servicing of the equipment



Caution: Risk of Electric Shock

Scope

This product range includes multiple functions:

AC Ammeters
AC Voltmeters
DC Ammeters and milliammeters
DC Voltmeters and millivoltmeters

Marking and ratings

Barrel side labels show function and electrical rating. The terminals are connected directly across the input to be measured.

Note that the electrical rating may differ from the dial scale marking, and the unit side label is definitive.

These meters are intended for a rated temperature range of 0-60 deg C and up to 80% relative humidity for temperatures up to 31 deg C, decreasing linearly to 50% relative humidity at 60 deg C, and only for indoor use and at an altitude of less than 2000m.

Installation

The meter should be installed in line with the requirements of the National Electrical Code (NEC) for USA or Canadian Electrical Code (CEC) for Canada. It should be installed in a dry position, not in direct sunlight and where the ambient temperature is reasonably stable and will not be outside the range noted above. These units are only for built in use, with terminals inaccessible to users after installation and should be mounted to an ANSI panel cut-out as shown over the page. Where fitted, current transformer (CT) secondaries must be connected to protective earth in accordance with local regulations. Do not tighten the mounting nuts beyond the torque necessary to secure the meter to the panel.

Fusing and connections

Terminals are suitable for use with insulated ring lugs. Ensure a minimum spacing of 0.21 inches (5.5mm) between uninsulated parts of adjacent ring lugs. Fit the supplied lock nut to each terminal after the first nut to ensure that connections cannot come loose in service. Tighten terminal nuts to 2Nm (1.5 ft/Lb) only.

Wiring must comply with class 1 requirements.

These products do not have internal fuses therefore external fuses **must** be used for safety protection under fault conditions.

Voltage input lines where required must be fused with a quick blow fuse 1A maximum. Current metering circuits directly connected in line with the load must be fused at the rated current for the meter, unless the circuit into which they are connected is limited so that it cannot deliver excessive current. Do not fuse CT circuits.

The equipment into which this meter is installed must have an adjacent means of isolating the supply voltage to permit safe access for subsequent maintenance.

External voltage transformers (PTs) and current transformers may be used where appropriate to extend the range, provided that the ratings marked on the side label are not exceeded at point of connection to meter. These products are designed for permanently connected use, normal condition measurement category III, pollution degree 2 (e.g. non ventilated panels or ventilated panels with filters, without condensation occurring), basic insulation, for rated voltage.

Choice of associated components

A table giving guidance on choice of fuses, connection cable and ring lugs is shown over the page.

Choose fuses of a voltage rating equal to or exceeding the rated voltage of the circuit into which the meter is connected and of a type and with a breaking capacity appropriate to the supply to which the fuse is connected.

Connection wires and ring lugs should be approved for at least 1A for voltage and auxiliary lines and to at least the rated current for current measuring circuits. Additionally, wires for current meters rated over 50mA must be rated at 75 deg C or greater. Ensure cables and ring lugs have a voltage insulation rating equal to or greater than the rated voltage of the circuit to which they are connected.

Note that minimum wire current ratings for CT circuits ensure that the wire is capable of carrying the current safely, however it may be desirable to use heavier gauge wiring, particularly for long cable runs to ensure that the CT VA rating is not exceeded and it's accuracy impaired.

Cleaning and maintenance

As required, wipe the front face with a damp cloth, ensuring that no moisture enters the unit or penetrates behind the mounting panel. No maintenance is required beyond periodically checking the mechanical zero of the meter as described below in "commissioning", if necessary removing any accumulations of dust or other foreign matter from the terminal area and ensuring that connections remain tight.

Warning

- During normal operation, voltages hazardous to life may be present at some of the terminals of this unit. Installation and maintenance should be performed only by qualified, properly trained personnel' abiding by local regulations. Ensure all supplies are de-energised before attempting connection or other procedures.
- Never open circuit the secondary winding of an energised current transformer.
- If this equipment is used in a manner not specified by the manufacturer, protection provided by the equipment may be impaired.

Electromagnetic Compatibility

This unit has been designed to provide protection against EM (electromagnetic) interference in line with requirements of FCC and other regulations. Precautions necessary to provide proper operation of this and adjacent equipment will be installation dependent and so the following can only be general guidance:-

- Avoid routing wiring to this unit alongside cables and products that are, or could be, a source of interference.
- The auxiliary supply to the unit should not be subject to excessive interference. In some cases, a supply line filter may be required.
- To protect the product against incorrect operation or permanent damage, surges and transients must be controlled. It is good EMC practice to suppress transients and surges at the source.
- Screened small signal leads are recommended and may be required. Connecting leads may require the fitting of RF suppression components, such as ferrite absorbers or line filters
- It is good practice to install sensitive electronic instruments that are performing critical functions in EMC enclosures that protect against electrical interference causing a disturbance in function.

For assistance on protection requirements please contact your local sales office.

Commissioning

The units are calibrated at the factory for full accuracy. No further adjustments are required except to check the zero position. With the meter in the intended attitude, adjust the centre slotted adjuster for scale zero without electrical input signal. It is recommended that after installation, test signals are applied to confirm correct indication.

Selection of fuses, connection cable and ring lugs

Circuit	Fuse Rating	Connection wire rating	Ring lug rating
Voltage and auxiliary lines	1A, voltage rating no less than highest circuit voltage connected to meter	1A, voltage rating no less than highest circuit voltage connected to meter	1A, voltage rating no less than highest circuit voltage connected to meter
Current circuit measuring whole current	Current rating as meter rated current, voltage rating no less than voltage of circuit being measured	Current rating as meter rated current, voltage rating no less than voltage of circuit being measured. For DC current circuits rated at greater than 50mA,	Current rating as meter rated current, voltage rating no less than voltage of circuit being measured
CT secondary	CT circuits should not be fused	Current rating* as meter rated current, voltage rating no less than voltage of circuit being measured. A wire with a temperature rating of greater than 75 deg C must be used.	Current rating as meter rated current, voltage rating no less than voltage of circuit being measured

Choose UL approved fuses, connection wires and ring lugs if the installation is to be to UL requirements or CSA approved items if the installation is to be to CSA requirements.

*Note that minimum wire current ratings for CT circuits ensure that the wire is capable of carrying the current safely, however it is often desirable to use larger gauge wiring, particularly for long cable runs to ensure that the CT VA rating is not exceeded and it's accuracy impaired.

Dimensions (mm / inches)

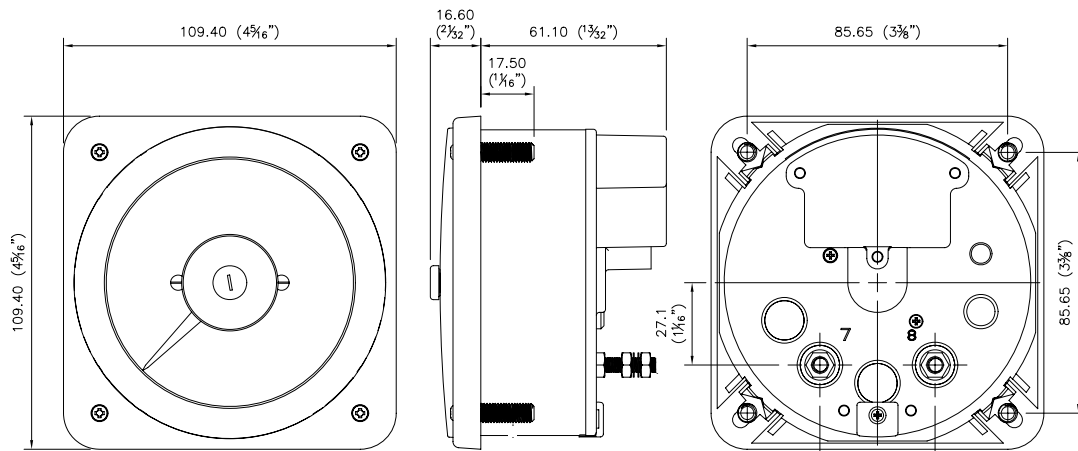

Panel Cut Out

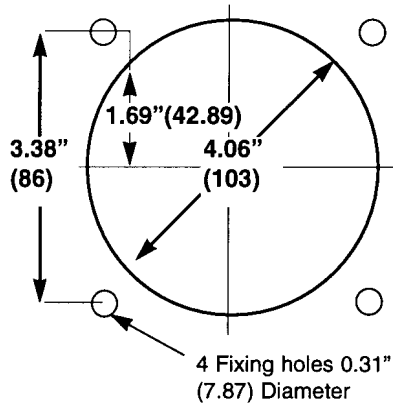

Tyco Electronics UK Limited
 Energy Division
 Freebournes Road, Witham, Essex, CM8 3AH, UK

Phone: +44 (0)870 870 7500
 Fax: +44 (0)870 240 5287
 www.crompton-instruments.com



All of the above information, including drawings, illustrations and graphic designs, reflects our present understanding and is to the best of our knowledge and belief correct and reliable. Users, however, should independently evaluate the suitability of each product for the desired application. Under no circumstances does this constitute an assurance of any particular quality or performance. Such an assurance is only provided in the context of our product specifications or explicit contractual arrangements. Our liability for these products is set forth in our standard terms and conditions of sale.
 TE logo and Tyco Electronics are trademarks. CROMPTON is a trademark of Crompton Parkinson Ltd. and is used by Tyco Electronics under licence.

ANSI Switchboard 07X series Analogue Meters

Products Covered

07*-05*	07*-08*	07*-12	07*-13	07*-14*
07*-15*	07*-16*	07*-21*	07*-30*	07*-31*
07*-41*	07*-42*	07*-45*	07*-KH	077-DI*
077-DW*	077-DX*	077-DP*	077-DZ*	(* = varies)



Caution: Risk of Danger

These instructions contain important safety information: Read before starting installation or servicing of the equipment



Caution: Risk of Electric Shock

Scope

This product range includes a wide range of functions:

- AC Ammeters and maximum demand meters
- AC Voltmeters
- DC Ammeters and milliammeters
- DC Voltmeters and millivoltmeters
- Elapsed time meters
- Frequency meters
- AC wattmeters, var meters and combined watt/watthour meters
- Power factor meters and rotary synchrosopes

Marking and ratings

Barrel side labels show function, electrical rating, and connection diagram, where there are more than two terminals on the unit. For two terminal units, the terminals are connected directly across the input to be measured.

For multiple terminal units, terminal numbers are moulded into the base adjacent to each terminal stud and corresponding numbers appear on the connection diagram. Note that the electrical rating may differ from the dial scale marking, and the unit side label is definitive. These meters are intended for a rated temperature range, is 0-40 deg C for 077 models and 0-60 deg C for 077-DI and models 077-21/31) and up to 80% relative humidity for temperatures up to 31 deg C, decreasing linearly to 50% relative humidity at 40 deg C, and only for indoor use at an altitude of less than 2000m.

Installation

The meter should be installed in line with the requirements of the National Electrical Code (NEC) for USA or Canadian Electrical Code (CEC) for Canada. It should be installed in a dry position, not in direct sunlight and where the ambient temperature is reasonably stable and will not be outside the range noted above. These units are only for built in use, with terminals inaccessible to users after installation and should be mounted to an ANSI panel cut-out as shown over the page. The case must be earthed via one or more of the mounting studs, and where fitted, current transformer (CT) secondaries must be connected to protective earth in accordance with local regulations. Do not tighten the mounting nuts beyond the torque necessary to secure the meter to the panel.

Fusing and connections

Connection diagrams shown on the unit side label should be carefully followed to ensure correct polarity and phase rotation where applicable. Terminals are suitable for use with insulated ring lugs. Ensure a minimum spacing of 0.21 inches (5.5mm) between uninsulated parts of adjacent ring lugs. Fit the supplied lock nut to each terminal after the first nut to ensure that connections cannot come loose in service. Tighten terminal nuts to 2Nm (1.5 ft/Lb) only. Wiring must comply with class 1 requirements.

These products do not have internal fuses therefore external fuses **must** be used for safety protection under fault conditions.

Voltage input lines where required must be fused with a quick blow fuse 1A maximum. Auxiliary supply lines, where required must be fused with a slow blow fuse rated 1A maximum. Current metering circuits directly connected in line with the load must be fused at the rated current for the meter. Do not fuse CT circuits.

The equipment into which this meter is installed must have an adjacent means of isolating the supply voltage to permit safe access for subsequent maintenance.

External voltage transformers (PTs) and current transformers may be used where appropriate to extend the range, provided that the ratings marked on the side label are not exceeded at point of connection to meter. These products are designed for permanently connected use, normal condition measurement category III, pollution degree 2 (e.g. non ventilated panels or ventilated panels with filters, without condensation occurring), basic insulation, for rated voltage. For 077-D* products, auxiliary power supply circuits are separated from metering inputs by at least basic insulation in accordance with IEC1010-1 (UL 61010-1 second edition) Permanently connected use, Normal Condition Measurement category III, pollution degree 2, for rated voltage.

Choice of associated components

A table giving guidance on choice of fuses, connection cable and ring lugs is shown over the page.

Choose fuses of a voltage rating equal to or exceeding the rated voltage of the circuit into which the meter is connected and of a type and with a breaking capacity appropriate to the supply to which the fuse is connected.

Connection wires and ring lugs should be approved for at least 1A for voltage and auxiliary lines and to at least the rated current for current measuring circuits. Additionally, wires for DC current meters rated over 50mA must be rated at 75 deg C or greater. Ensure cables and ring lugs have a voltage insulation rating equal to or greater than the rated voltage of the circuit to which they are connected.

Note that minimum wire current ratings for CT circuits ensure that the wire is capable of carrying the current safely, however it may be desirable to use heavier gauge wiring, particularly for long cable runs to ensure that the CT VA rating is not exceeded and it's accuracy impaired.

Cleaning and maintenance

As required, wipe the front face with a damp cloth, ensuring that no moisture enters the unit or penetrates behind the mounting panel. No maintenance is required beyond periodically checking the mechanical zero of the meter as described overleaf in "commissioning", if necessary removing any accumulations of dust or other foreign matter from the terminal area and ensuring that connections remain tight.

Warning

- During normal operation, voltages hazardous to life may be present at some of the terminals of this unit. Installation and maintenance should be performed only by qualified, properly trained personnel' abiding by local regulations. Ensure all supplies are de-energised before attempting connection or other procedures.
- Never open circuit the secondary winding of an energised current transformer.
- If this equipment is used in a manner not specified by the manufacturer, protection provided by the equipment may be impaired.

Electromagnetic Compatibility

This unit has been designed to provide protection against EM (electromagnetic) interference in line with requirements of FCC and other regulations. Precautions necessary to provide proper operation of this and adjacent equipment will be installation dependent and so the following can only be general guidance:-

- Avoid routing wiring to this unit alongside cables and products that are, or could be, a source of interference.
- The auxiliary supply to the unit should not be subject to excessive interference. In some cases, a supply line filter may be required.
- To protect the product against incorrect operation or permanent damage, surges and transients must be controlled. It is good EMC practice to suppress transients and surges at the source.
- Screened small signal leads are recommended and may be required. Connecting leads may require the fitting of RF suppression components, such as ferrite absorbers or line filters
- It is good practice to install sensitive electronic instruments that are performing critical functions in EMC enclosures that protect against electrical interference causing a disturbance in function.

For assistance on protection requirements please contact your local sales office.

All of the above information, including drawings, illustrations and graphic designs, reflects our present understanding and is to the best of our knowledge and belief correct and reliable. Users, however, should independently evaluate the suitability of each product for the desired application. Under no circumstances does this constitute an assurance of any particular quality or performance. Such an assurance is only provided in the context of our product specifications or explicit contractual arrangements. Our liability for these products is set forth in our standard terms and conditions of sale.

Commissioning

The units are calibrated at the factory for full accuracy. No further adjustments are required except to check the zero position. With the meter in the intended attitude, adjust the centre slotted adjuster for scale zero without electrical input signal. It is recommended that after installation, test signals are applied to confirm correct indication and that, where applicable, CT phasing is correct and voltage and current connections match.

Selection of fuses, connection cable and ring lugs

Circuit	Fuse Rating	Connection wire rating	Ring lug rating
Voltage and auxiliary lines	1A, voltage rating no less than highest circuit voltage connected to meter	1A, voltage rating no less than highest circuit voltage connected to meter	1A, voltage rating no less than highest circuit voltage connected to meter
Current circuit measuring whole current	Current rating as meter rated current, voltage rating no less than voltage of circuit being measured	Current rating as meter rated current, voltage rating no less than voltage of circuit being measured. For DC current circuits rated at greater than 50mA, a wire with a temperature rating of greater than 75 deg C must be used.	Current rating as meter rated current, voltage rating no less than voltage of circuit being measured
CT secondary	CT circuits should not be fused	Current rating* as meter rated current, voltage rating no less than voltage of circuit being measured	Current rating as meter rated current, voltage rating no less than voltage of circuit being measured

Choose UL approved fuses, connection wires and ring lugs if the installation is to be to UL requirements or CSA approved items if the installation is to be to CSA requirements.

*Note that minimum wire current ratings for CT circuits ensure that the wire is capable of carrying the current safely, however it is often desirable to use larger gauge wiring, particularly for long cable runs to ensure that the CT VA rating is not exceeded and it's accuracy impaired.

Dimensions (mm / inches)

	Dia	C	D	E	F	G
75	103/4.1	110/4.3	17/0.7	*	11/0.4	101/4.0
77	103/4.1	110/4.3	17/0.7	*	30/1.2	101/4.0
78	103/4.1	110/4.3	17/0.7	*	30/1.2	101/4.0
79	229/9.0	229/9.0	17/0.7	*	30/1.2	101/4.0

* Dimension E varies according to product and case style, either 56mm/2.2", 86mm/3.4" or 132mm/5.2"

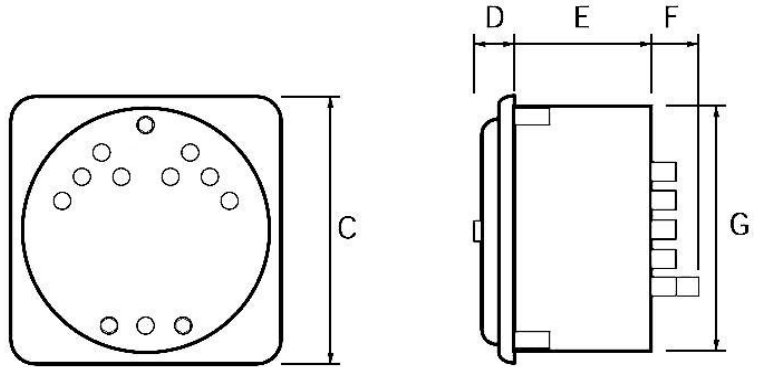

Panel Cut Out

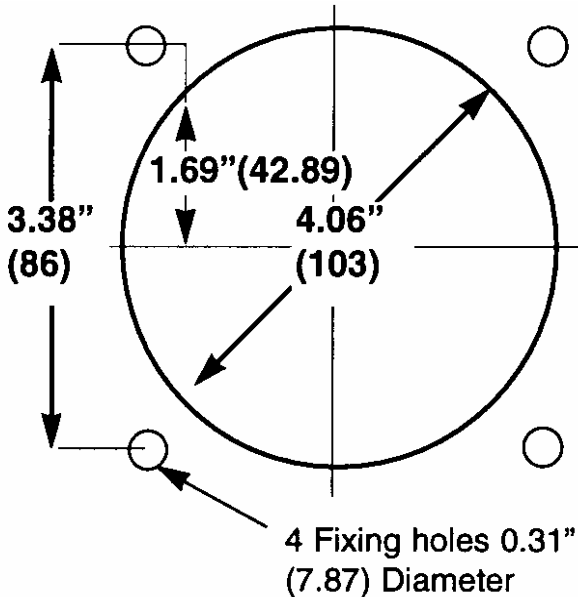

Tyco Electronics UK Limited
 Energy Division
 Freebournes Road, Witham, Essex, CM8 3AH, UK

Phone: +44 (0)870 870 7500
 Fax: +44 (0)870 240 5287
 www.crompton-instruments.com



All of the above information, including drawings, illustrations and graphic designs, reflects our present understanding and is to the best of our knowledge and belief correct and reliable. Users, however, should independently evaluate the suitability of each product for the desired application. Under no circumstances does this constitute an assurance of any particular quality or performance. Such an assurance is only provided in the context of our product specifications or explicit contractual arrangements. Our liability for these products is set forth in our standard terms and conditions of sale.
 TE logo and Tyco Electronics are trademarks. CROMPTON is a trademark of Crompton Parkinson Ltd. and is used by Tyco Electronics under licence.